



# Mark your Plastic

**U510** UV laser technology

For permanent codes on plastics and films



Domino. Do more.

# Crisp codes, high contrast

Our **U510** laser is ideally suited for creating indelible, highly precise coding onto today's plastic packaging materials.

The UV laser can code directly onto white and coloured substrates without the need for laser activated fields.

Designed for Industry 4.0 requirements the compact all-in-one **U510** integrates easily into modern production lines.



## Class leading precision, code clarity, and contrast

- ◆ The **U510** applies pin-sharp human- and machine-readable codes
- ◆ Codes are bright white on dark plastics and deep black on white plastics
- ◆ The powerful laser tube (6W at 100kHz) is ideal for high-speed and on-the-fly applications
- ◆ With a marking field up to 326x326mm the **U510** is particularly suitable for wide web applications

## Ease of integration

- ◆ The compact all-in-one controller and laser unit makes production line integration easy
- ◆ Fan cooling removes the need for water or factory air
- ◆ The adjustable **U510** scan-head can be mounted in horizontal or vertical orientation
- ◆ Vision system integration enables automated code inspection
- ◆ Easy audit trail implementation helps to achieve a compliant solution

## Uptime and reliability

- ◆ Domino Cloud enables remote diagnostics and 24/7 visibility of your lasers' performance
- ◆ Domino's **SafeGuard** service and support plans ensure optimised uptime and take the risk out of investment
- ◆ The **U510** unit is dust and water protected (IP55) for reliable operation and long lifetime even in challenging production environments



# Ideal application fit

The **U510** UV laser excels on modern, sustainable packaging developments such as recyclable flexible mono-material polymers, including thin films.

- ◆ Keeping the protective barrier intact: coding is achieved by a photochemical reaction in the very top layer of the packaging material without causing any damage. The **U510** laser pulse has an extremely short wavelength and high absorption rate which minimises thermal stress and soot particle build. Even very thin, sensitive packaging films can be coded safely.
- ◆ Coding white and coloured plastics: the laser pulse reacts with titanium dioxide (TiO<sub>2</sub>) to achieve highly contrasting codes. TiO<sub>2</sub> is contained in many plastics, so the laser can code anywhere on these products without the need for additives or laser activated fields on many substrates.

		U510 laser
Flexible film (recyclable)		✓
High and Low Density Polyethylene (HDPE / LDPE) white		✓
High and Low Density Polyethylene (HDPE / LDPE) colours		✓
Polypropylene (PP) light colours		✓
Polypropylene (PP) dark colours		✓



## A trusted partner

Domino's laser labs are at hand to test your substrate and determine the best laser coding solution for your requirements. Our global team of in-house scientists will analyse your substrate using spectroscopic techniques; identify the appropriate solution, and create samples for further testing and analysis. Substrate testing includes 3D microscope imaging to measure the impact of the code on the substrate. Our scientific approach means that we can find the solution that best fits your application.

## A complete solution

Our services are designed to provide operational insight so you can eliminate downtime and maximise production efficiency



### Fume extraction

Domino's DPX fume extraction systems effectively filter fume and particulate debris from the coding process. Maintaining a dust-free operating area helps manufacturers to protect their equipment, maximise uptime and maintain a high code quality.

### Operational support

An outstanding level of care, wherever you are. Our **SafeGuard** packages provide high-quality, on-site assistance and AR-enabled remote guidance from our engineers. **SafeGuard** helps to ensure we can be with you when you need us most.

### Automatic code inspection

Ensure every code that leaves your factory is present and correct, and free up operator time. With the R-Series, Domino's range of vision control systems, you can automate your code inspection to validate code presence, placement, and readability.

### Smart production

Gain operational insight by connecting your printer to Domino Cloud. Obtain production analytics dashboards and receive system error alerts. Domino Cloud provides you with the information you need to run your operations more efficiently.

## Technical specification

### U510

Coding laser	
Laser type	YVO <sub>4</sub> - THG, class 4
Wavelength	355nm (invisible)
Nominal output power	6W (from the laser) / 4.5W (from the coder)
Laser oscillation	Pulsed, duration 5–50ns, frequency 0–500 kHz
Focal length / marking field	160mm/100x100mm, 330mm/207x207mm, 480mm/326x326mm
Aiming beam laser (integrated)	
Laser type	Laser diode, class 2
Wavelength	655nm (visible)
Laser oscillation	Continuous wave
Coder specification	
Electrical requirements	100-240 VAC, max. 3A, 50/60 Hz
Maximum power consumption	300 VA
Maximum peak laser power	12 W
Code types and fonts	Logos, bar codes, 2D codes, graphics, text, etc. / 16 fonts, multi-language including full Unicode
Character height	0.6 mm—marking field size
Dimensions	580 x 180 x 200 mm (L x W x H) / 21 kg
Ingress protection	IP55
Operating temperature	10–40°C
Operating relative humidity	Max. 90% RH, non-condensing
Cooling	Air cooled (fan)
Finish	Anodised aluminium construction
Performance level (PL)	ISO13849-1:2015 Category 4 PL <sub>e</sub> considered from the safety inputs
Operating system	Laser coder: embedded Linux / user interface: Windows® 10
Optional touch screen	10.4" <b>TouchPanel</b> with LMEEditor QS
Communication	Dynamark protocol, Domino Cloud Interface (DCI)

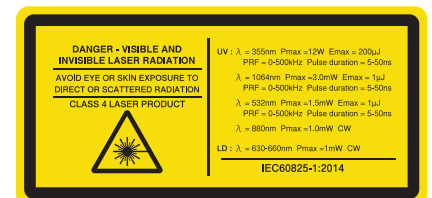
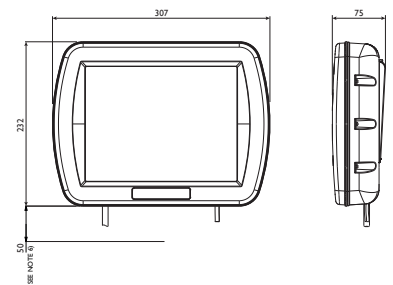
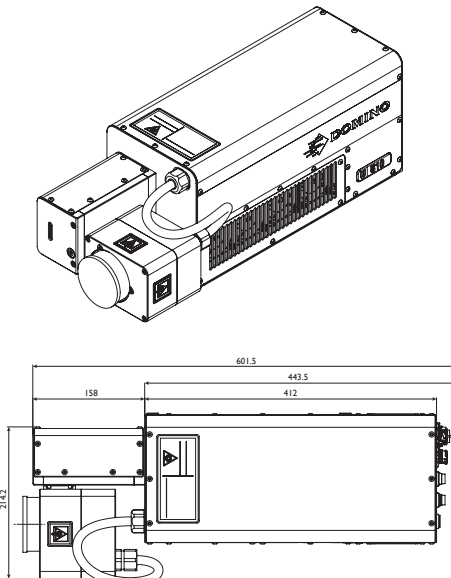
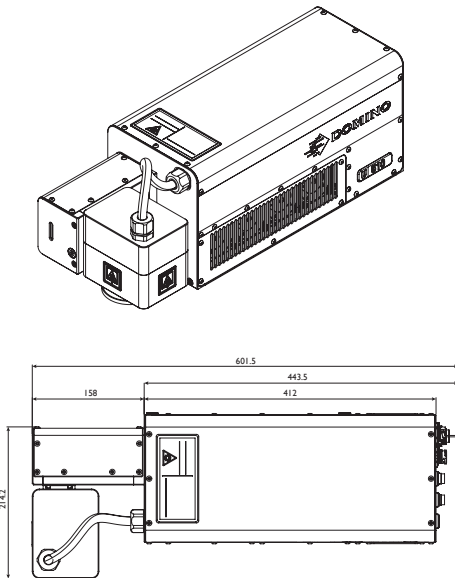

## TALK TO AN EXPERT

enquiries@domino-uk.com  
 +44 1954 782 056 (Sales & Service)  
 www.domino-printing.com